

4-CHLOROPHENYL 5-CHLORO-8-QUINOLYL PHOSPHOROTETRAZOLIDE:
A HIGHLY EFFICIENT PHOSPHORYLATING AGENT FOR OLIGORIBONUCLEOTIDE SYNTHESIS

Hiroshi TAKAKU*, Tadaaki NOMOTO, and Kazuo KAMAIKE
Laboratory of Organic Chemistry, Chiba Institute of Technology,
Narashino-shi, Chiba 275

4-Chlorophenyl 5-chloro-8-quinolyl phosphorotetrazolide (2) was a highly efficient phosphorylating agent for the synthesis of 5'-O-dimethoxytrityl-2'-O-tetrahydropyranylnucleoside 3'-(4-chlorophenyl, 5-chloro-8-quinolyl) phosphates (4). The fully protected ribonucleoside 3'-phosphotriesters 4 are key intermediates for the synthesis of oligoribonucleotides via phosphotriester approach.

In a previous paper, we have described 4-chlorophenyl 5-chloro-8-quinolyl phosphorochloridate prepared simply from 4-chlorophenyl phosphorodichloridate and 5-chloro-8-hydroxyquinoline in one flask reaction. The phosphorochloridate could be used for the preparation of 5'-O-dimethoxytrityl-2'-O-tetrahydropyranylnucleoside 3'-(4-chlorophenyl, 5-chloro-8-quinolyl) phosphates (4) as a key intermediate in the synthesis of oligoribonucleotides by the phosphotriester approach.¹ However, we observed some dimethoxytrityl alcohol and 5'-phosphorylated products during the phosphorylation of 3'-hydroxyl group of 5'-O-dimethoxytritylnucleoside using 4-chlorophenyl 5-chloro-8-quinolyl phosphorochloridate (1). In order to clarify such side reactions, we examined the reaction of 1 and 5'-O-dimethoxytrityl-2',3'-O-dibenzoyluridine. To a solution of 4-chlorophenyl phosphorodichloridate (0.83 ml, 5.0 mmol) in dry THF was added a mixture of solution of 5-chloro-8-hydroxyquinoline (987 mg, 5.5 mmol) and triethylamine (7.5 ml, 5.5 mmol) in dry THF (12.5 ml) at -10°C. The reaction mixture was gradually warmed to room temperature and stirred for 45 min.¹ After completion of the reaction, triethylammonium hydrochloride was removed by filtration. To the filtrate was added 5'-O-dimethoxytrityl-2',3'-O-dibenzoyluridine (755 mg, 1.0 mmol) and 1-methylimidazole (0.6 ml, 7.5 mmol). The mixture was kept for 8 h at room temperature, quenched with ice-water, and extracted with methylene chloride (3 X 30 ml). The methylene chloride extract was washed with water, and concentrated in vacuo. The residue was dissolved in a small amount of methylene chloride and chromatographed on a silica gel column. The undesirable nucleoside 5'-phosphotriester (5) was found to be isolated in 120 mg (15%) by eluting the column with methylene chloride-methanol (95:5 v/v).²

In order to overcome this problem, 4-chlorophenyl 5-chloro-8-quinolyl phosphorotetrazolide (2) was employed in place of 1 as a phosphorylating agent.

A typical procedure for the phosphorylation of the 3'-hydroxyl of 2',5'-protected nucleoside using 2 is as follows: To a solution of 4-chlorophenyl

phosphorodichloridate (0.25 ml, 1.5 mmol) in dry THF (2.5 ml) at -10°C was added a solution of 5-chloro-8-hydroxyquinoline (287 mg, 1.6 mmol) in dry THF (2 ml). After 15 min, triethylamine (0.22 ml, 1.6 mmol) in dry THF (1.2 ml) was added, and the reaction mixture was gradually warmed to room temperature and stirred for 45 min. A mixture of tetrazole (122 mg, 1.7 mmol) and triethylamine (0.23 ml, 1.7 mmol) in dry THF (3.5 ml) was added. After 10 min, triethylammonium hydrochloride was removed by filtration. To the filtrate was added 5'-O-dimethoxytrityl-2'-O-tetrahydropyranyl- N^6 -benzoyladenine (758 mg, 1.0 mmol). The solution was concentrated to 4 ml under reduced pressure and stirred for 30 min at room temperature. The solution was concentrated to obtain a gummy material and it was dissolved in methylene chloride. The methylene chloride solution was washed with water, dried over anhydrous sodium sulfate and concentrated. The residue was dissolved in a small amount of methylene chloride and chromatographed on a silica gel short column. The desired nucleoside 3'-phosphotriester 4b was isolated in 1.05 g (95%) by eluting the column with a stepwise gradient of methanol (0-5%) in methylene chloride.

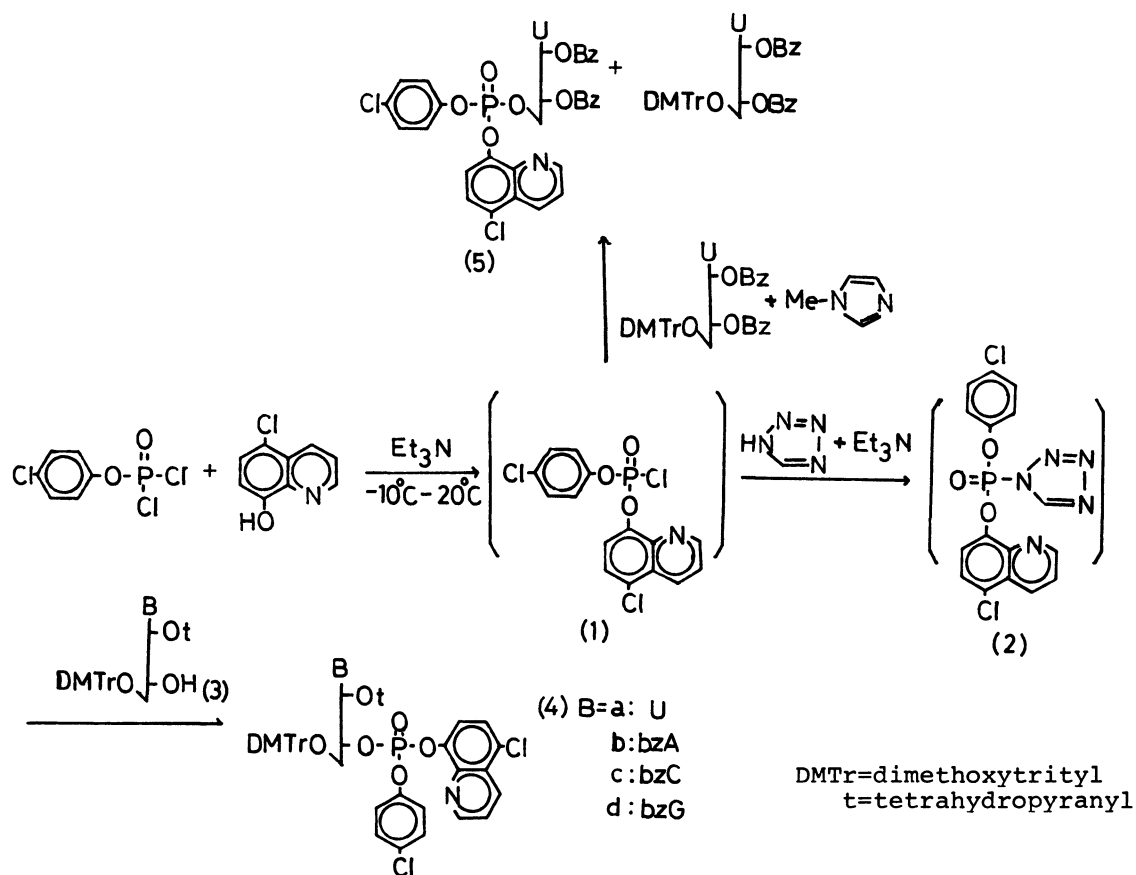

Similarly, other monoribonucleoside 3'-phosphotriesters 3a, 3c, and 3d were obtained in 96%, 91%, and 88% yields, respectively. Dedimethoxytritylation and the corresponding 5'-phosphorylation were not observed during the phosphorylation reactions. Furthermore, 2 afforded 4d containing guanine base from 3d in high

yield than the use of 1 *in situ*. However, in the above reactions, when triazole was used in place of tetrazole, the yield of 4a from 3a decreased markedly to 20%. The phosphorylating agent 2 cannot be isolated, however, it can be kept in THF for several days at -10°C . All nucleotidic compounds 4 were homogeneous on HPLC and identified by ^1H NMR and gave satisfactory elemental analysis.

Next, the synthesis of a trinucleotide (CpCpAp) (10) by using 4 was examined. The phosphotriester 4b (2.22 g, 2.0 mmol) was treated with 2% p-toluenesulfonic acid in a mixture of dioxane and methanol (7:3 v/v) for 15 min at 0°C to give 6.³ The 5'-hydroxyl nucleoside 3'-phosphotriester (6) was isolated in 1.57 g (97%) by precipitation with petroleum ether and used for next coupling reaction without further purification. On the other hand, 4c (2.83 g, 2.9 mmol) was treated with 1M $\text{N}^1, \text{N}^1, \text{N}^3, \text{N}^3$ -tetramethylguanidium salt of 2-pyridinaldoxime (3.0 ml) in a mixture of dioxane and water (1:1 v/v) (54 ml) for 16 h at 20°C .¹ The mixture was treated with Dowex 50W-X2 (pyridinium form) and the resin was removed by filtration and washed with aqueous pyridine (50%). The filtrate and washings were combined and washed with ether and extracted with methylene chloride. The methylene chloride extract was rendered anhydrous by repeated coevaporation with dry pyridine. The

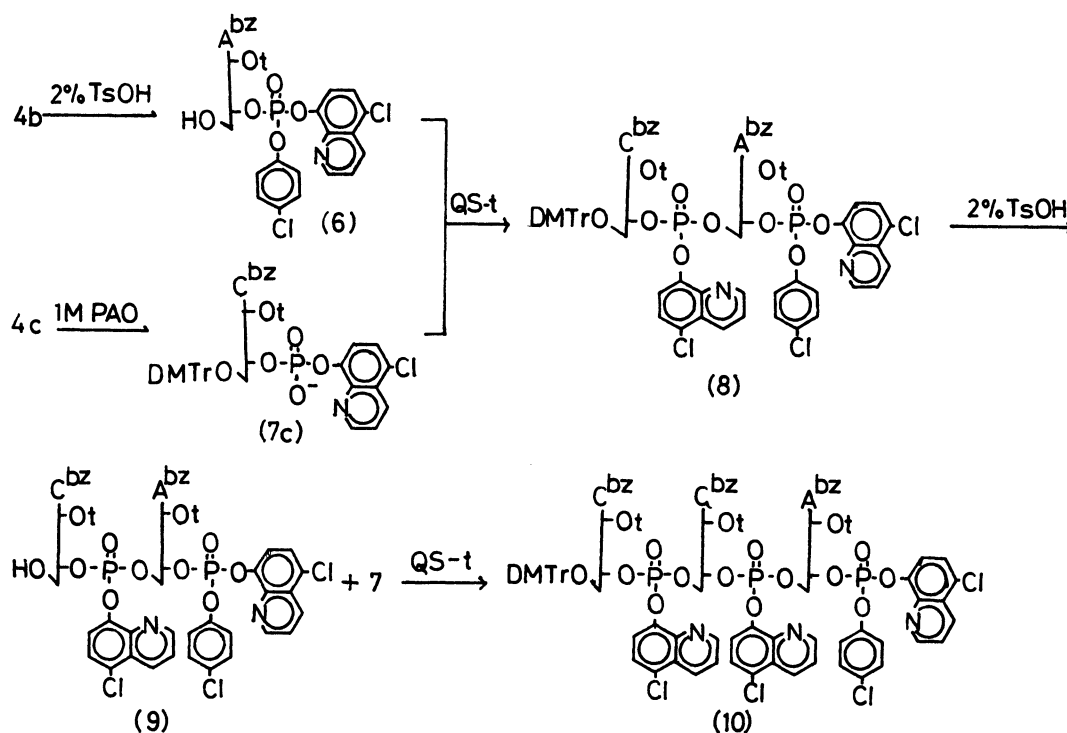

1. conc. NH_4OH

2. HCl (pH 2)

3. ZnCl_2 (pyridine/ H_2O)

CpCpAp

PAO=2-pyridinaldoxime
QS-t=8-quinolinesulfonyl-
tetrazole

phosphodiester (7c)⁴ thus obtained was dissolved in dry pyridine (9 ml) and then 6 (1.57 g, 1.9 mmol) and 8-quinolinesulfonyltetrazolide (QS-t)⁵ (1.53 g, 5.8 mmol)

were added. The reaction mixture was stirred for 1 h. After removal of 8-quinolinesulfonic acid⁶ by filtration, the corresponding dinucleotide (CpAp) (8) was obtained in 3.37 g (97%) after separation by silica gel short column chromatography. The trinucleotide 10 was prepared analogous by as described above for the synthesis of the dinucleotide 8. The compound 4c (1.07 g, 1.1 mmol) was treated with 1M N¹,N¹,N³,N³-tetramethylguanidium salt of 2-pyridinaldoxime⁷ to remove the 4-chlorophenyl group and the phosphodiester 7c thus obtained was condensed with the partially protected dinucleotide (9) (1.05 g, 0.73 mmol) using QS-t (726 mg, 2.75 mmol) for 1 h to give the fully protected trinucleotide (10) in 85% (1.49 g) isolated yield. Compound 10 was deprotected using first conc. ammonia for 5 h at 50°C to remove the benzoyl and 4-chlorophenyl groups, and then with 0.01N hydrochloric acid (pH 2) for 20 h at 20°C to split off the dimethoxytrityl and tetrahydropyranyl groups, and finally with zinc chloride in aqueous pyridine for 24 h at room temperature to remove the 5-chloro-8-quinolyl group.^{1,5,8,9,10} The deblocked trinucleotide, CpCpAp was obtained in 87% yield after purification by chromatography on DEAE-cellulose DE-52. The purity of CpCpAp was checked by TLC, PE, and HPLC on Finepak C₁₈¹¹ as well as hydrolysis with spleen phosphodiesterase to Cp and Ap in the ratio 2.01:1.00.

In conclusion, it was found that 4-chlorophenyl 5-chloro-8-quinolyl phosphotetrazolide (2) was a highly efficient phosphorylating agent for the synthesis of nucleoside 3'-phosphotriesters bearing 5'-dimethoxytrityl group.

The authors thanks Professor Tsujiaki Hata for his encouragement and his discussion throughout the investigation.

REFERENCES AND NOTES

1. H.Takaku, M.Yoshida, K.Kamaike, and T.Hata, *Chem.Lett.*, 1981,197.
2. 5: TLC on silica gel, Rf=0.50 (CH₂Cl₂-MeOH, 9;1 v/v): mp 90-93°C: UV λ_{max} (MeOH) 258 and 233 nm, λ_{min} (MeOH) 251 nm: Anal. Calcd for C₃₈H₂₆N₃O₁₁Cl₂P: C, 56.86; H, 3.27; N, 5.24. Found: C, 57.06; H, 3.50; N, 5.07.
3. H.Takaku, R.Yamaguchi, T.Nomoto, and T.Hata, *Tetrahedron Lett.*, 1979,3857.
4. The phosphodiester 7a-d were isolated in almost quantitative yields by precipitation as pyridinium salts with petroluem ether. The ³¹P NMR spectra (pyridine as solvent and 85% H₃PO₄ as external standard) of 7a-d are as follows; 7a: δ +5.67 and +6.32 (Rf=0.78); 7b: δ +5.55 and +6.08 (Rf=0.82); 7c: δ +5.35 and +6.12 (Rf=0.84); 7d: δ +6.12 and +6.47 (Rf=0.80); 5-chloro-8-quinolyl phosphate: δ +3.34. TLC was performed on Merck cellulose F using ethanol-1M ammonium acetate (5:3 v/v).
5. H.Takaku and M.Yoshida, *J.Org.Chem.*, 46, 589(1981).
6. H.Takaku, M.Yoshida, M.Kato, and T.Hata, *Chem.Lett.*, 1979,811.
7. C.B.Reese, R.C.Titmas, and L.Yau, *Tetrahedron Lett.*, 1978,2727.
8. H.Takaku, T.Nomoto, Y.Sakamoto, and T.Hata, *Chem.Lett.*, 1979,1225.
9. H.Takaku, M.Kato, M.Yoshida, and R.Yamaguchi, *J.Org.Chem.*, 45,3347(1980).
10. H.Takaku, T.Nomoto, M.Murata, and T.Hata, *Chem.Lett.*, 1980,1419.
11. Elution was performed with 4% acetonitrile containing 0.1M ammonium acetate (pH 7.5).

(Received February 5, 1981)